

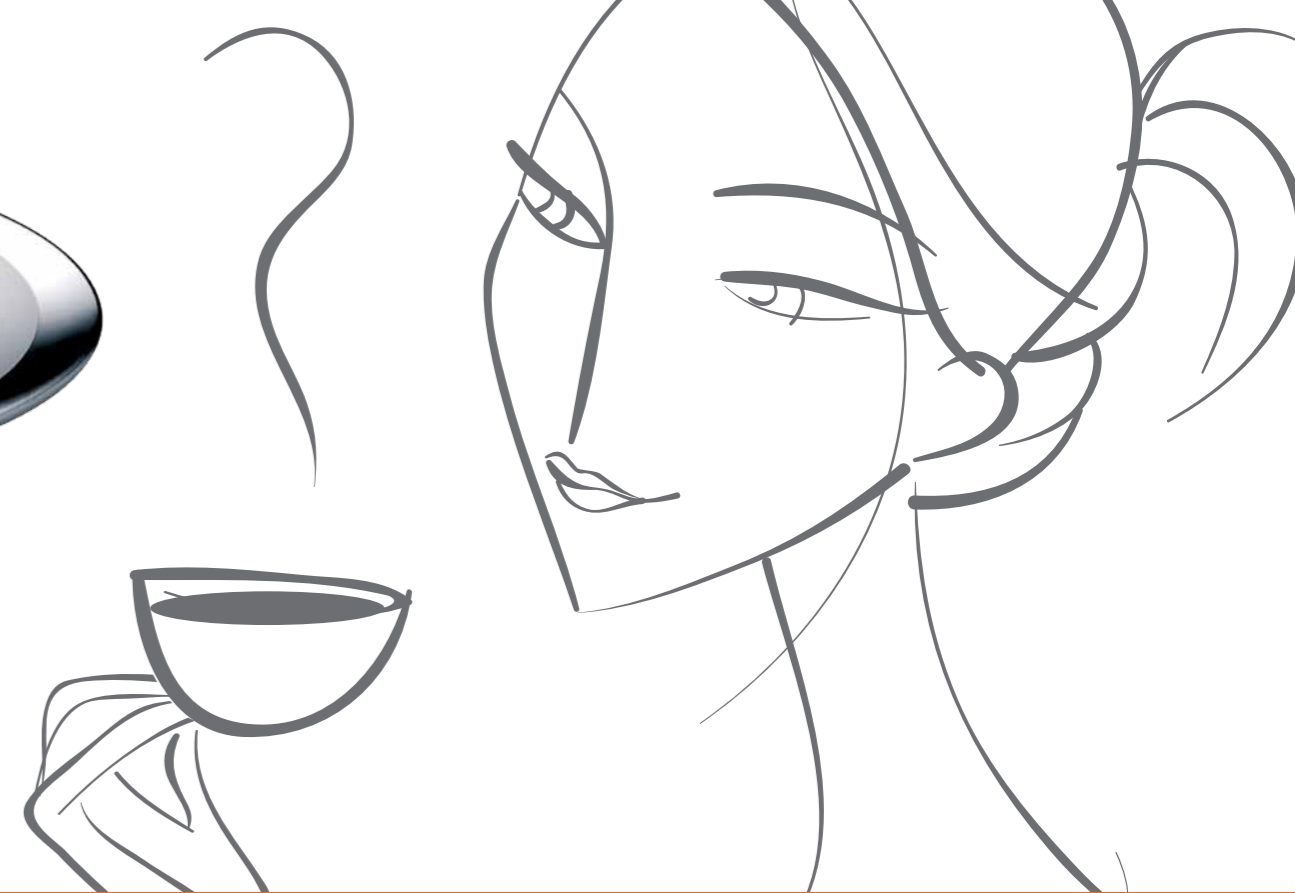

THE BARISTA'S CHOICE



brasilia **espresso** machines
www.brasilia.co.uk

The BEST extraction The BEST espresso
The BEST cappuccino The BEST machines

brasilia **espresso** machines

SOLE UK IMPORTER



Caffe Society
Unit 2, Lincoln Way, Sherburn-in-Elmet,
Leeds, LS25 6PJ
Web: www.caffesociety.co.uk
Email: info@caffesociety.co.uk
Tel: 0845 4500500 - Fax: 0845 4500499



BRASILIA: AN INTRODUCTION

Established in 1977 and based in Retorbido Italy, BRASILIA manufactures and distributes traditional espresso machines to over 100 markets across 6 continents. Renowned market leaders and innovators, Brasilia strives to keep its position as the world's most desired and successful premium coffee machine manufacturer. Brasilia espresso machines provide the best commercial solutions in terms of styling, reliability and functionality, with models to suit businesses of all sizes and types. Brasilia have revolutionised the outlook towards traditional style equipment by developing easy to follow training programmes and dispelling the myth that traditional coffee machines are too complicated for a mainstream operation.



Brasilia Headquarters in Retorbido, Italy



Brasilia Italy's Barista training centre

CAFFE SOCIETY LTD ARE THE SOLE UK IMPORTER FOR BRASILIA ESPRESSO MACHINES

ABOUT CAFFE SOCIETY
Caffe Society have been supplying espresso machines for many years in the UK. We have a large customer base ranging from independent bars and restaurants to national multiple sites.



DEMONSTRATION AND TRAINING

Our custom built premises has a state of the art showroom where we are always pleased to welcome existing and potential customers to demonstrate the benefits of our wide range of coffee machines and grinders. It is here where our coffee experts carry out Barista training which is available to all our customers. Onsite training is also available.

SERVICE AND SUPPORT

Our nationwide support team of highly skilled and experienced engineers cover the installation, servicing and repair of all our espresso machines and coffee grinders. For further details, either phone us on 0845 4500500 or email us at sales@brasilia.co.uk

brasiliaespressomachines

WHY CHOOSE BRASILIA?

- The widest range of commercial espresso machines with models and pricing to suit businesses of any size
- The best performing, best looking and most reliable machines in the world
- All Italian design and craftsmanship
- Designed for ease of use and maintenance
- The best brewing systems
 - Rossi Brewing System as standard
 - E61 Brewing System (on Opus)
 - Bullone Rosso Brewing System (standard on Excelsior)
 - Sublima Brewing System (standard on Opus Sublima)
- Tall cup versions available as standard to accommodate large takeaway cups and latte glasses
- National training centres staffed by the UK's leading baristas
- The largest stock of espresso machines in the UK for speedy delivery and installation
- An outstanding range of professional coffee grinders
- The largest nationwide service network with 24 hour on site call out service
- Brasilia are members of the SCAE, IFL, ESE, ANIMA, UCIMAC and are represented in 100 countries World wide

BELLE EPOQUE

The stunning Belle Epoque combines the latest espresso technology within a "Liberty" original style compact outer case. Perfect for historical bars and restaurants or locations with "olde worlde" interiors. The Belle Epoque will add the "Wow!" factor for instant visual impact in any coffee house.



KEY FEATURES

- Brewing groups can be arranged for combined use with pods (for special blends, decaffeinated and infusions) and ground coffee
- 1 steam arm
- 1 hot water tap
- Automatic boiler water level
- Boiler water level gauge
- Compact boiler size with smaller element
- Hand built by Italian craftsmen
- 1 and 2 group models available to order (allow 6-8 weeks)
- Available in: copper / brass, full brass finish, full chrome finish, golden (solid gold-plated 24K)

OPTIONS / AVAILABILITY

- Non stock item, hand built by Italian craftsmen
- 1 and 2 group models available to order (allow 6-8 weeks)
- Available in: copper / brass, full brass finish, full chrome finish, golden (solid gold-plated 24K)

SPECIFICATIONS

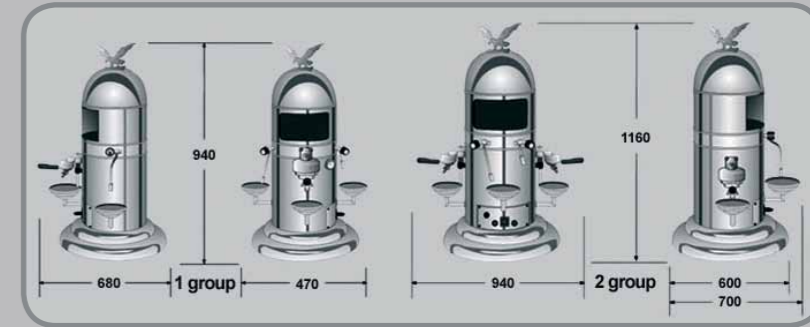

| Groups | Boiler Capacity | Voltage | Heating Elements | Electrical Input | Weight | Dimensions |
|--------|-----------------|-----------------|------------------|------------------|--------|---------------------|
| 1 | 2.5 litre | 240v / 50hz / 1 | 1700w | 7.4A | 39kg | W470 x H940 x D680 |
| 2 | 5 litre | 240v / 50hz / 1 | 2400w | 10.5A | 54kg | W940 x H1160 x D700 |

brasilia – THE BARISTA'S CHOICE

In independent research carried out by IPSOS with 50 leading Italian Baristas, the Brasilia Opus Sublima out performed ALL its major competitors (including the World Barista Championship machine) and produced 30% better coffee extraction, aroma and milk texture.

Opus Sublima is 1 of only 3 espresso machines to be accepted and accredited by the World Barista Championship as a fully accurate system for temperature, (+/- 0.5 degree) coffee extraction, milk foam and aroma.

EXCELSIOR TALL CUP

The Excelsior stands head and shoulders above every other machine in the world. It fuses together all Brasilia's manufacturing and design experience to create the finest coffee with a style unmatched. Brasilia produces the best performing and most attractive machines on the market and the Excelsior is the jewel in the crown. It has a real 'wow' factor and appeals to restaurants, hotels, cafes and bars where the most discerning of clients expect the very best.



KEY FEATURES

- Electronic control system with auto-diagnostic facility
- Raised machine – ideal for 16oz cups, china mugs, takeaway cups, tall latte glasses etc
- Fully automatic delivery system that caters for all cup volumes as well as continuous delivery system and programmable dispensing keys
- Retractable cup rests easily accommodate different cup sizes
- Large-capacity boiler offers continuous dispensing and strong steam supply
- Stainless steel wands for steam with 'high-flow' nozzle design
- Cup warmer means drinks stay hot for longer
- Brew groups can be arranged for use with coffee pods making it ideal for decaffeinated, origin coffees, special blends and ground coffee
- Brew groups have pre-infusion device and automatic washing and rinsing cycles
- Boiler water level gauge / automatic boiler water level
- The wide circular base acts as a large drip tray and a real working area for the drinks preparation

SUPERIOR COFFEE EXTRACTION

- Brewing groups with pre-infusion device
- Each brew group's water temperature can be separately controlled by a 3 position flow selector for perfect espresso from any blend
- Temperature stability of +/- 0.5°C at all working temperatures and conditions
- Bullone Rosso is able to extract espresso even more effectively than lever machines

OPTIONS

- Standard Height or Tall Cup models
- 2 and 3 group models available
- Available in: Chrome with Red, Black, Silver or Orange

SPECIFICATIONS



| Groups | Boiler Capacity | Voltage | Heating Elements | Electrical Input | Weight | Dimensions |
|--------|-----------------|-----------------|------------------|------------------|--------|---------------------|
| 2 Std | 11.4 litre | 240v / 50hz / 1 | 3500w | 16.1A | 80kg | W850 x H560 x D585 |
| 3 Std | 18 litre | 240v / 50hz / 1 | 5000w | 22.6A | 97kg | W1060 x H560 x D585 |
| 2 Tall | 11.4 litre | 240v / 50hz / 1 | 3500w | 16.1A | 85kg | W850 x H650 x D585 |
| 3 Tall | 18 litre | 240v / 50hz / 1 | 5000w | 22.6A | 102kg | W1060 x H650 X D585 |

BULLONE ROSSO ADVANCED BREWING SYSTEM COMES AS STANDARD WITH THE EXCELSIOR

Thanks to a new Brasilia technology, a special brewing water temperature profile allows espresso extraction and temperature stability levels higher than other professional espresso machines on the market and even higher than traditional lever machines.



OPUS

The Opus epitomises everything that Brasilia stands for. It features a stunning Italian design style, exceptional build quality and produces coffee that's so good customers can't resist coming back for more. Designed by Italy's famous Architettura Laboratorio, the Brasilia Opus is a real focal point for any bar, restaurant or hotel with a chic and contemporary interior.



Standard Height



Tall Cup

KEY FEATURES

- Solid die-cast aluminium cabinet
- Italian design by Architettura Laboratorio
- Rossi brewing technology
- Fully automatic with controlled volumetric delivery by keypad (plus push button for continuous delivery)
- Electronic control for precise volumetric dosing - programmable dispense keys
- Raised group heads allow up to 16oz takeaway cups or tall latte glasses
- Large capacity boiler for continuous dispensing and high volume steam supply
- Automatic boiler water level
- Boiler water level gauge
- 2 swivelling steam arms with "Caoutchouc" handgrip to protect fingers
- Moveable hot water tap
- Large capacity electrical cup warmer
- Ergonomically curved group handles
- Brew groups can be arranged for combined use with pods

OPTIONS / AVAILABILITY

- 2 and 3 group models available
- Colours:
Tall Cup - Black and Grey / Red and Grey / All black (above right)
Standard Height - Black and Grey / Red and Grey (above left)

SPECIFICATIONS

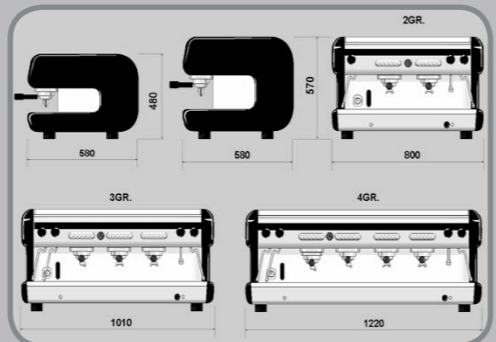

| Groups | Boiler Capacity | Voltage | Heating Elements | Electrical Input | Weight | Dimensions |
|--------|-----------------|-----------------|------------------|------------------|--------|---------------------|
| 2 Std | 11.4 litre | 240v / 50hz / 1 | 3500w | 16.1A | 76kg | W800 x H480 x D580 |
| 3 Std | 18 litre | 240v / 50hz / 1 | 5000w | 22.6A | 90kg | W1010 x H480 x D580 |
| 4 Std | 24.5 litre | 240v / 50hz / 1 | 6500w | 27.9A | 104kg | W1220 x H480 x D580 |
| 2 Tall | 11.4 litre | 240v / 50hz / 1 | 3500w | 16.1A | 77kg | W800 x H570 x D580 |
| 3 Tall | 18 litre | 240v / 50hz / 1 | 5000w | 22.6A | 100kg | W1010 x H570 x D580 |
| 4 Tall | 24.5 litre | 240v / 50hz / 1 | 6500w | 27.9A | 113kg | W1220 x H570 x D580 |

OPUS SUBLIMA

The Opus is already one of the best machines on the market but when you add the Sublima Brewing System to it, the results are phenomenal. Temperature and brewing cycle for each group head can be independently and accurately controlled allowing high flexibility for different coffee blends. You have to taste its espresso and cappuccino to believe how good it really is.



Standard Height - Pro Version



Tall Cup - Easy Version

Sublima – The new frontier in brewing technology

The Opus Sublima is available in two versions:

SUBLIMA EASY: for the less experienced barista featuring a single steam arm with twin position lever control and a hyperwand for automatic frothed or steamed milk.

SUBLIMA PRO: a version for the experienced barista featuring two standard steam arms.

The Sublima system will change the way you evaluate espresso machines and we would encourage you to try the machine to see and taste the difference for yourself.

Let the new espresso era begin!

brasiliaopuswithsublimasystem

THE BEST ESPRESSO MACHINE ON THE MARKET

KEY FEATURES

Two different versions are available:

Sublima Easy with one Hyperwand and one standard steam arm. The Hyperwand is an automatic steam arm. Simply place the steam arm in a jug of milk and press steam or froth, set the temperature and within seconds you have perfect milk! The standard swivelling steam arm features a twin position lever control and handgrip to protect fingers.

Sublima Pro with two standard swivelling steam arms, with handgrips and tap operation.

- Double display user interface
- Temperature control over the main boiler, group heads and group head balancing boiler
- All adjustable via PID settings providing +/- 0.5°C temperature variance
- Sublima brewing technology, 14 bar brewing pressure for superb extraction
- Energy efficient, individual heads can be switched off to save power
- Multi boiler system with adjustable timed pre infusion and water pressure controller for each group

- Two hot water outlets, one providing boiling water for tea & one with adjustable cold water injection ideal for Americano
- Brew groups can be arranged for combined use with pods (for special blends, decaf and infusions) and ground coffee
- Produces the best microfoamed milk for the perfect cappuccino
- Fully automatic with controlled volumetric delivery by keypad (plus push button for continuous delivery)
- Raised group heads allow up to 16oz takeaway cups or tall latte glasses
- Retractable cup rests to accommodate standard cup heights
- Solid die-cast aluminium body
- Large capacity stainless steel boiler for continuous dispensing and high volume steam supply
- Boiler water level gauge
- Italian design by Architettura Laboratorio
- Ergonomically curved group handles

SPECIFICATIONS

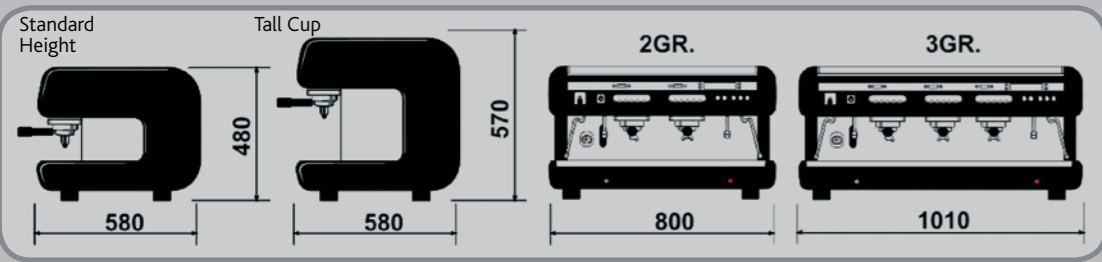

| Groups | Boiler Capacity | Voltage | Heating Elements | Electrical Input | Weight | Dimensions |
|--------|-----------------|-----------------|------------------|------------------|--------|---------------------|
| 2 Std | 11.4 litre | 240v / 50hz / 1 | 4700w | 20.5A | 76kg | W800 x H480 x D580 |
| 3 Std | 18 litre | 240v / 50hz / 1 | 6800w | 29.7A | 93kg | W1010 x H480 x D580 |
| 2 Tall | 11.4 litre | 240v / 50hz / 1 | 4700w | 20.5A | 83kg | W800 x H570 x D580 |
| 3 Tall | 18 litre | 240v / 50hz / 1 | 6800w | 29.7A | 99kg | W1010 x H570 x D580 |

OPTIONS

- Standard Height or Tall Cup models
- 2 and 3 group models available
- Easy and Pro versions available
- Colours: Tall Cup - Black and Grey / Red and Grey / All black
Standard Height - Black and Grey / Red and Grey

Easy Version with automatic hyperwand



Pro Version with traditional steam arm



14 BAR PRESSURE

Emulating the increased pressure available on traditional lever machines, the Sublima's PressurePlus brewing cycle operates at 14 bar for a fuller extraction. This allows almost 50% better extraction compared to other traditional machines (max 9 Bar) and a far superior crema.

SUPERB THERMAL STABILITY WITH FULL STEAM POWER

The Tempdrive balancing system has 3 levels of temperature control - main boiler, group head and group head balancing boiler. This allows stability of +/- 0.5°C, at the same time retaining full steam pressure.

TEMPERATURE CONTROL & STABILITY

Coffee is extremely sensitive to the changes in water temperature. If the water making it is too cool then your espresso can be acidic and sour, too hot and it can be burnt and bitter. Sublima's independent group head balancing boilers and PID system ensure a stable temperature to assist the barista in making a great coffee every time.

ULTIMATE FLEXIBILITY FOR DIFFERENT COFFEE BLENDS

Different coffees require different temperatures to draw out the balance of flavours. The Sublima gives you more control than any other machine. You can independently alter the temperature of each group head balancing boiler, the temperature of the group itself and adjust the PID settings. Hydroactive S2 Architecture allows the full infusion cycle for each group head to be independently controlled.

FAST & CREAMY CAPPUCCINOS

Sublima froths milk 30% quicker than other machines, producing the best microfoamed milk possible.

POWERFUL STEAM CAPACITY

Pressure in the main boiler can be set high to give you great steam capacity for busy cafés making lots of cappuccinos and lattes. With traditional espresso machine technology this would increase the temperature of the water making your coffee and potentially burn it. Due to Sublima's group head balancing boilers this is prevented.

CHOOSE YOUR PRE-INFUSION TIME

Pre infusion is often linked to coffee quality. The Sublima's twin solenoid valves per group allow you to control the pre infusion time to your requirements.

ENERGY EFFICIENCY

Group heads can be switched off independently allowing you to save energy at quieter times.

CHOOSE YOUR HOT WATER TEMPERATURE

The Sublima has two hot water spouts. One drawing water directly from the main boiler providing the perfect temperature for brewing black tea, and one that can be adjusted for cooler temperatures for making Americano (without burning the espresso!).

USER FRIENDLY DISPLAY

A simple user interface to monitor and control all brewing parameters.



The BEST extraction The BEST espresso The BEST cappuccino The BEST machine

MAJORE PLUS

The best selling Brasilia Majore Plus traditional coffee machine combines classic Italian styling with a full stainless steel finish and is guaranteed to look amazing wherever it is placed. The addition of Brasilia's new B09 brew group gives excellent performance and thermal stability for perfect coffee every time. Double steam arms ensure your cappuccinos and lattes keep flowing however busy you get.



KEY FEATURES

- Traditional espresso machine with classic polished stainless steel design style
- Raised group heads allow for takeaway cups
- Moveable hot water tap to fill teapots or Americanos
- Fully automatic delivery system that caters for all cup volumes as well as continuous delivery system
- Two "cold touch" steam wands
- Cup warmer means drinks stay hot for longer
- Brew groups can be arranged for use with coffee pods making it ideal for decaffeinated, origin coffees, special blends and ground coffee
- Rossi brewing system with B09 brewing groups
- Digital Display

OPTIONS / AVAILABILITY

- 2 and 3 group models available

SPECIFICATIONS

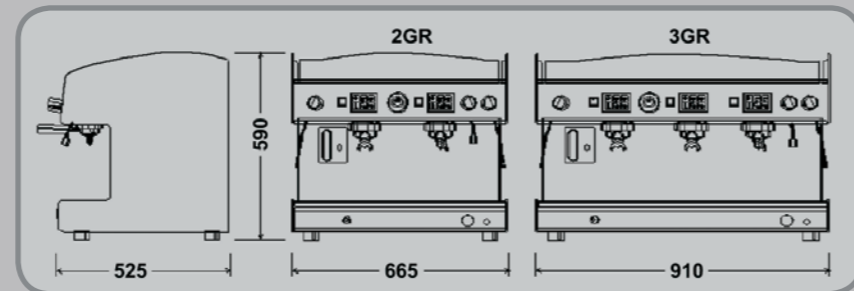

| Groups | Boiler Capacity | Voltage | Heating Elements | Electrical Input | Weight | Dimensions |
|--------|-----------------|-----------------|------------------|------------------|--------|--------------------|
| 2 | 11.4 litre | 240v / 50hz / 1 | 3500w | 15.4A | 69kg | W665 x H590 x D525 |
| 3 | 18 litre | 240v / 50hz / 1 | 5000w | 21.7A | 79kg | W910 x H590 x D525 |

CADETTA

The perfect machine for any business entering the premium coffee market. The Cadetta offers Brasilia's superb build quality along with delicious tasting coffee making it the perfect choice for a full range of venues. With its top specification, large boiler and striking design style, the Cadetta fits comfortably in any environment. It's simple to operate, extremely reliable and it's great coffee will keep customers coming back for more.



KEY FEATURES

- Large capacity boiler for continuous dispensing and high volume steam supply
- Automatic boiler water level
- Boiler water level gauge
- 1 swivelling steam arm
- Moveable hot water tap
- Rossi brewing system
- Large cup warmer
- Brew groups can be arranged for combined use with pods (for special blends, decaf and infusions) and ground coffee

OPTIONS / AVAILABILITY

- 2 and 3 group models available
- Semi and fully automatic versions

SPECIFICATIONS

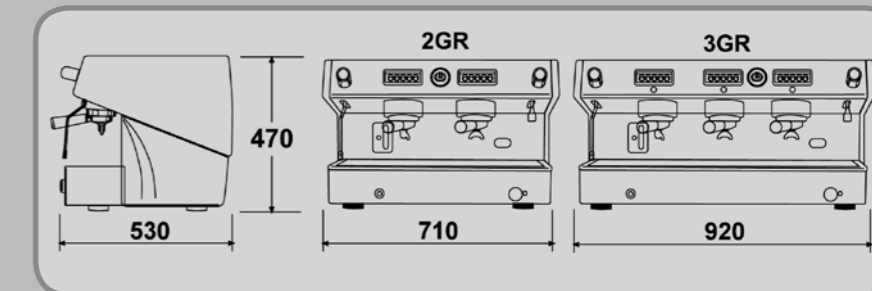

| Groups | Boiler Capacity | Voltage | Heating Elements | Electrical Input | Weight | Dimensions |
|--------|-----------------|-----------------|------------------|------------------|--------|--------------------|
| 2 | 11.4 litre | 240v / 50hz / 1 | 3500w | 15.4A | 69kg | W710 x H470 x D530 |
| 3 | 18 litre | 240v / 50hz / 1 | 5000w | 21.7A | 79kg | W920 x H470 x D530 |

CADETTA COMPACT

The Brasilia Cadetta Compact is the perfect traditional coffee machine for any business entering the premium coffee market with limited counter space. It offers Brasilia's superb build quality along with delicious tasting coffee making it the perfect choice for a full range of venues.

With its top specification and striking design style, the Cadetta fits comfortably in any environment. It's simple to operate, extremely reliable and its great coffee will keep customers coming back for more.



KEY FEATURES

- Small footprint
- Boiler water level gauge / automatic boiler water level
- 1 swivelling cold touch steam arm
- 1 Moveable hot water tap to fill teapots or Americanos
- Rossi brewing system
- Large cup warmer
- Brew groups can be arranged for combined use with pods (for special blends, decaf and infusions) and ground coffee

OPTIONS / AVAILABILITY

- 1 and 2 group models available

SPECIFICATIONS

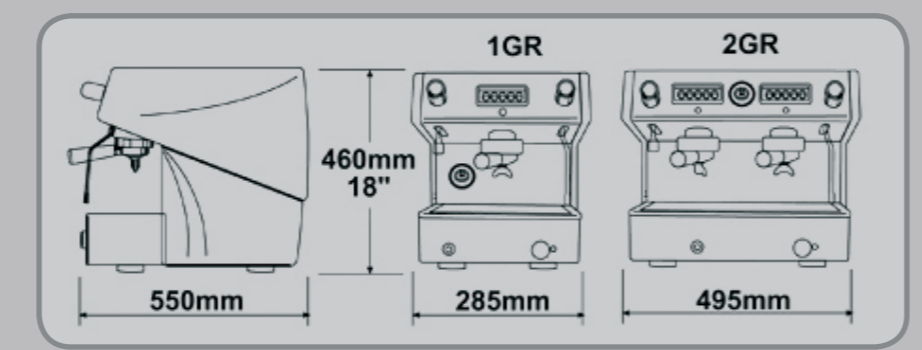

| Groups | Boiler Capacity | Voltage | Heating Elements | Electrical Input | Weight | Dimensions |
|--------|-----------------|-----------------|------------------|------------------|--------|--------------------|
| 1 | 2.6 litre | 240v / 50hz / 1 | 1800w | 13A | 30.5kg | W285 x H460 x D550 |
| 2 | 5 litre | 240v / 50hz / 1 | 2400w | 13A | 43kg | W495 x H460 x D550 |

RR550D

On demand coffee grinder meaning that the beans are ground only when required, ensuring freshly ground coffee for every cup.



KEY FEATURES

- Single and double dose buttons.
- Variable grinding time settings so that dosing quantities can be changed if required
- Micrometric adjusting device
- Flat grinder burr
- Fixed press tamp
- Quiet operation - noise level of only 69dB, one of the quietest coffee grinders on the market

SPECIFICATIONS

- Bean hopper capacity: 1.2 kg
- Productivity: 9 kg/hour
- 64mm flat burr
- Speed: 1380 RPM
- Weight: 10.5 kg
- Voltage: 240 V
- Power: 175W
- Silver painted body

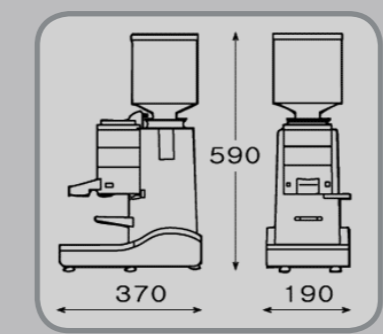

RR55A

Automatic professional coffee grinder with flat grinder burr and micrometric adjusting device.



KEY FEATURES

- Micrometric adjusting device
- Flat grinder burr
- Fixed press tamp
- Quiet operation - noise level of only 69dB, one of the quietest coffee grinders on the market

SPECIFICATIONS

- Bean hopper capacity: 1.2 kg
- Doser capacity: 250 g
- Productivity: 9 kg/hour
- 64mm flat burr
- Speed: 1380 RPM
- Weight: 10.5 kg
- Voltage: 240 V
- Power: 175W
- Silver painted body

