

GIGA X3 Professional



PROFESSIONAL

Moving into the top class

The new GIGA X3 Professional offers everything needed by staff in a large office or staff room. It delivers up to 43 individually programmable speciality coffees at the touch of a button, including the en-vogue flat white. As well as offering simple operation, it takes minimum effort to refill thanks to the large bean container with a holding capacity of 1 kg and aroma preservation cover. Other features include an optional coffee grounds disposal function and drip drain set. Integrated rinsing and cleaning operations started at the touch of a button minimise the amount of work needed to maintain the machine on a daily basis. A large water tank and large coffee grounds container allow for flexible and mobile use.

Benefits

- Professional ceramic disc grinder
- Variable dual spout with 2 coffee spouts and 2 milk spouts
- Customisable start screen
- With optional coffee grounds and drip drain set

Technical overview

JURA standards

Variable brewing unit, from 5 g to 16 g	■
Intelligent Pre-Brew Aroma System (I.P.B.A.S.)	■
Intelligent preheating	■
Active bean monitoring	■
Energy Save Mode (E.S.M.)	2 levels
High-performance pump, 15 bar	2
Thermoblock heating system	2
Parallel fluid systems	2
CLARIS filter cartridge	CLARIS Pro Blue
Monitored drip tray	■
Maintenance status display	■
Integrated rinsing, cleaning and descaling programme	■
Adjustable water hardness	■
JURA hygiene TÜV-certified	■
Swiss made	■

Specific benefits

Customisable product names	■
Flat white at the touch of a button	2
Latte macchiato at the touch of a button	2
Caffè latte at the touch of a button	2
Cappuccino at the touch of a button	2
Pot of espresso-quality coffee	■
No. of individually programmable specialities	43
Milk or milk foam preparation selectable via electrically controlled air intake	■
JURA fine foam technology	■
Electrically adjustable ceramic disc grinders (5 levels)	1
Power hot water system (3 temperature levels)	approx. 0.5 l/min.
Powder recognition for second, ground coffee	■
TÜV certificate for user-friendly user manual	■

Settings and programming options

Intelligent Pre-Brew Aroma System with optional deactivation	■
Programmable amount of water	■
Amount of water can be adjusted for each preparation	■
Programmable coffee strength	5 levels
Coffee strength can be adjusted for each preparation	■
Programmable brewing temperature	3 levels
Programmable amount of milk	■
Programmable hot water temperature	3 levels

Rotary Switch for intuitive navigation	■
Programmable preparation buttons	8
Switch-on and switch-off times can be specified for each day of the week	■
Resettable day counter	■

Design and materials

Alu Frame Design 3 mm aluminium front	■
Centre panel in Piano Black	■
TFT colour display	■
Venti Ports	■
Height-adjustable dual spout (milk/coffee)	70 – 159 mm
Width-adjustable dual spout	20 – 50 mm
Height-adjustable hot-water spout	69 – 165 mm
Amber cup illumination	■
White cup illumination	■
Sound design	■

Accessories

Cup warmer	optional
Compressor Cooler Pro	optional
Accounting system	optional
Coffee grounds disposal set	optional
Drip drain set	optional
Coffee to Go equipment	optional
MDB interface unit	optional

In figures

Water tank capacity 5 l	5 l
Coffee grounds container (servings)	approx. 40
Bean containers with aroma preservation cover	1 kg
Cable length	approx. 1.1 m
Voltage	220 – 240 V AC/10 A
Power	2300 W
Weight	18.2 kg
Dimensions (W × H × D)	37 × 55 × 49.7 cm
Checks	CE (S)



Hygiene standards



www.tuv.com
ID 0000027526

Supplied by:

Caffe Society Ltd.

Tornado House, Moxon Way, Sherburn In Elmet, Leeds, LS25 6FB

Tel: 0845 4500 500

Web: www.caffesociety.co.uk Email: info@caffesociety.co.uk



jura

jura



JURA – If you love coffee

GIGA X3/X3c Professional

Supplied by:

Caffe Society Ltd.

Tornado House, Moxon Way, Sherburn In Elmet, Leeds, LS25 6FB

Tel: **0845 4500 500**

Web: www.caffesociety.co.uk Email: info@caffesociety.co.uk



Moving into the top class

The GIGA X3/X3c Professional delivers state-of-the-art technology for the perfect coffee wherever top-class performance is called for. The automatic speciality coffee machines provide everything required in a large office or staff room: up to 31 individually programmable speciality coffees at the touch of a button, including the in-vogue flat white, simple operation, minimum refilling thanks to the large, 1 kg holding capacity bean container with aroma preservation cover and the drip drain and coffee grounds disposal function set*.

The integrated rinsing and cleaning programmes can be started at the touch of a button, minimising the effort involved in day-to-day machine maintenance. Once you've tried it, you and your team won't want to be without it.

The move into the top class leaves nothing to be desired and you can choose from two models: the GIGA X3 with its large water tank and coffee grounds container for flexible, mobile use and the GIGA X3c with a permanent water connection for high-performance stationary use.

* The drip drain set comes as standard with the GIGA X3c and is an option with the GIGA X3. The coffee grounds disposal function set is optional.



GIGA X3c Professional

SWISS  MADE

Intuitive operation

The ingenious, self-explanatory operating concept includes a ball bearing-mounted Rotary Switch and TFT display for maximum speed and efficiency. 31 speciality coffees and another 12 barista recipes can be directly selected. The standard screen can be customised to the occasion or user, as can the names of the individual specialities.

As well as being easy to operate and programme, the machine is designed to be very easy to care for. Modern water treatment and filter systems optimise the water for an unrivalled taste experience. The integrated rinsing and cleaning programmes reduce the effort involved to a minimum and guarantee TÜV-certified hygiene at the touch of a button.



Unique design

This is a machine that doesn't need to shout to be heard. Pure, clean lines, high-quality materials, maximum precision and outstanding craftsmanship express its unique, competent and sovereign character. The front panel is produced from 3 mm thick solid aluminium. It brings the simple, minimalist forms so typical to JURA into their own.





Variable dual spout with fine foam technology

The GIGA technology even features an adjustable air intake, electronically controlled by a geared stepper motor, to heat and froth the milk. When you make a latte macchiato, the machine automatically dispenses hot milk into the glasses, followed immediately by milk foam and finally coffee. This makes preparation child's play and saves valuable time. The GIGA X3/X3c is also capable of producing the internationally popular flat white. The secret lies in the right sequence of coffee, hot milk and the characteristic crown of milk foam, which adds the final magical touch.

Ceramic disc grinder

A professional high-performance grinder, featuring specially positioned grinding discs made from wear-resistant technical ceramic, guarantees precise and consistently even grinding for years to come. It is amazingly fast, cutting grinding times in half compared with previous models. The grinder is adjusted electronically.



Drip drain set*

The convenient drip drain set is ideal for situations where beverages are dispensed continually, because it saves you from having to empty the drip tray during daily use. Each GIGA X3/X3c is prepared in the factory such that you can fit the set, comprising valve and pipe, in just a few simple steps.

* Standard with GIGA X3c, optional with GIGA X3

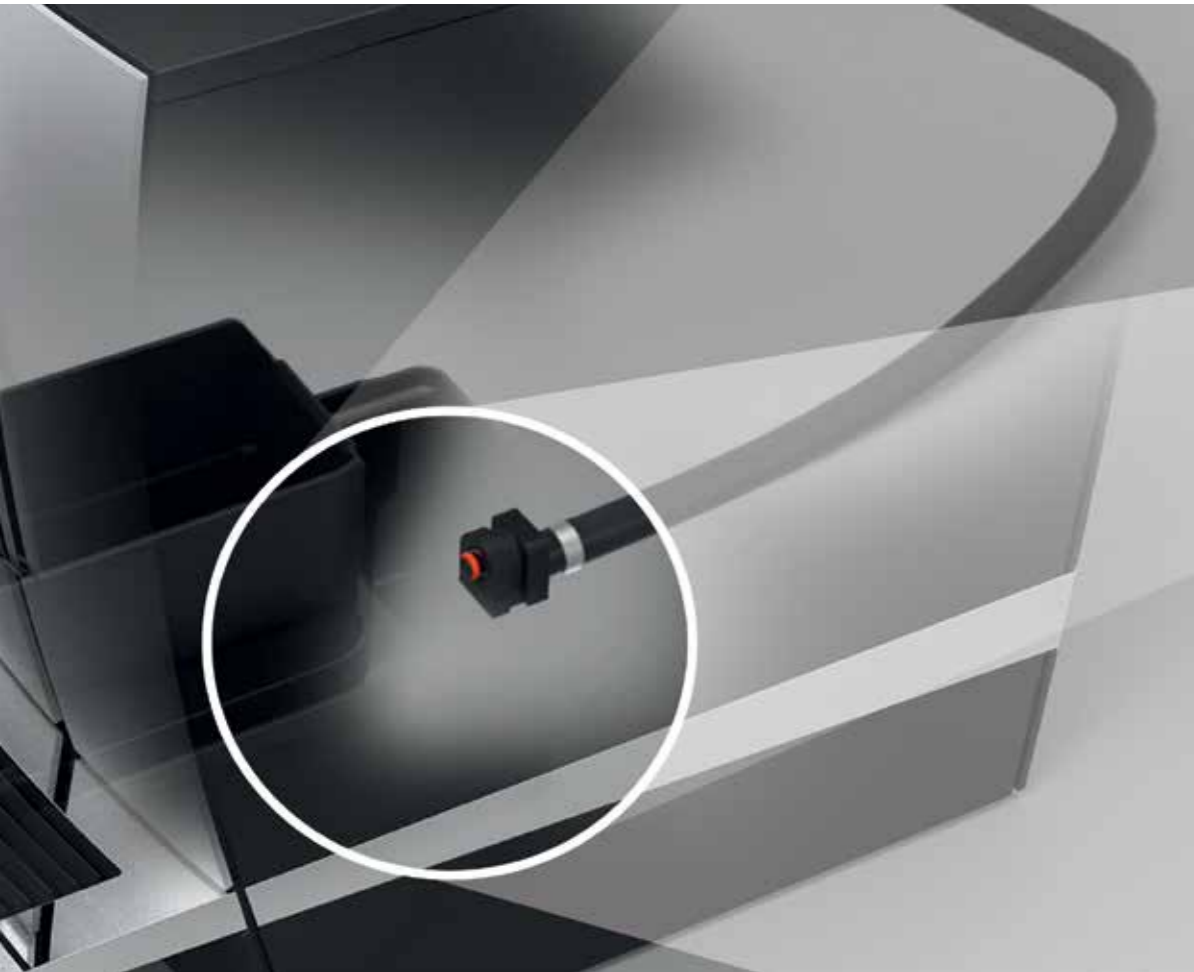

Optional coffee grounds disposal function set

The large capacity of the coffee grounds container means that emptying is only required every 40 preparations or so. With the coffee grounds disposal function set, even this is unnecessary. An uninterrupted supply of speciality coffees doesn't get any easier than this. Thanks to the special design of the coffee grounds container, the coffee grounds pass through the base plate. Your authorised JURA partner can quickly carry out the necessary modification.



Technical data

GIGA X3 Professional SWISS MADE

GIGA X3c Professional SWISS MADE

Customisable product names	■	■
Flat white at the touch of a button	1 of 2	1 of 2
Latte macchiato at the touch of a button	1 of 2	1 of 2
Caffè latte at the touch of a button	1 of 2	1 of 2
Cappuccino at the touch of a button	1 of 2	1 of 2
Power hot water system (3 temperature levels)	0.5 l/min.	0.5 l/min.
No. of individually programmable specialities	43	43
Programmable amount of coffee water	■	■
Amount of water can be adjusted for each preparation	■	■
Programmable coffee strength	5 levels	5 levels
Coffee strength adjustable for each preparation	■	■
A la carte bean selection (coffee selection)	■	■
Intelligent Pre-Brew Aroma System with optional deactivation	■	■
Programmable brewing temperature	3 levels	3 levels
Electrically adjustable ceramic disc grinder (5 levels)	1	1
Variable brewing chamber, from 5 g to 16 g	■	■
Intelligent Pre-Brew Aroma System (I.P.B.A.S.®)	■	■
Intelligent preheating	■	■
Height-adjustable dual spout	70 – 159 mm	70 – 159 mm
Width-adjustable dual spout	20 – 50 mm	20 – 50 mm
Height-adjustable hot-water spout	69 – 165 mm	69 – 165 mm
Automatic changeover from milk to milk foam	■	■
Cup illumination	Amber/white	Amber/white
Display	TFT colour display	TFT colour display
Active bean monitoring	■	■
Monitored drip tray	■	■
Maintenance status display (view cleaning / descaling / filter status and number of preparations)	■	■
Water tank fill volume	5 l	Permanent water connection
Bean container with aroma preservation cover	1 kg	1 kg
Voltage / power	220 – 240 V AC / 2300 W	220 – 240 V AC / 2300 W
Weight / dimensions (W × H × D)	18.2 kg / 37 × 55 × 49.7 cm	18.2 kg / 32 × 55 × 49.7 cm
Article number	15002 (Switzerland and EU)	15003 (Switzerland and EU)

GIGA X3/X3c Professional carries the following quality marks: CE 

The tailor-made complete solution

With a wide selection of accessories including cup warmers, milk coolers and accounting systems, as well as an attractive range of storage and presentation units, it is possible to create a complete coffee solution tailored to your specific requirements. For more information, visit www.jura.com or consult our authorised partners.

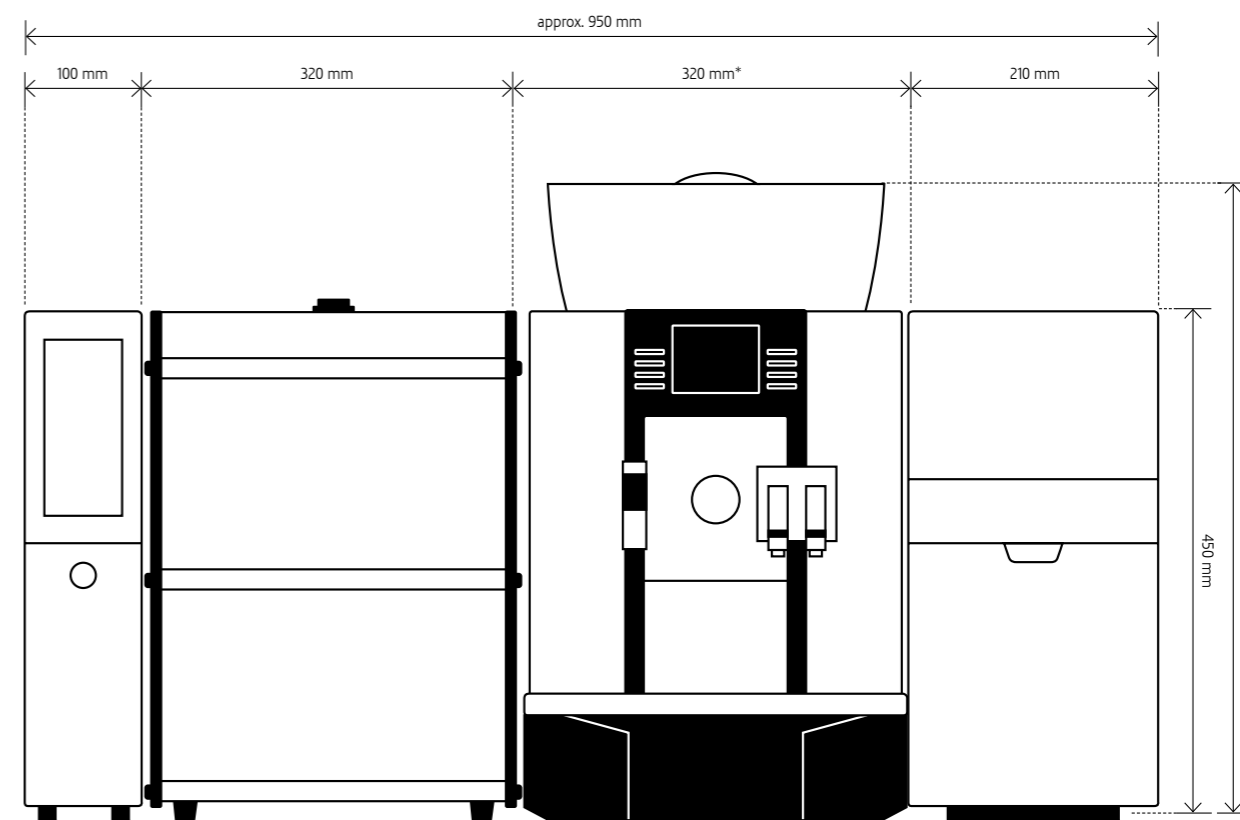

* GIGA X3 Professional: 370 mm